

# IMPORTANT INFORMATION



EST. 2004

ontario hearth ltd.

**Marquis Serene 47**

ZCVRB47NE/ZCVRB47LPE (IPI)

MQZCVRB47NE2/MQZCVRB47LPE2

(PROFLAME 2 IPI)

**FRAMING**

**DIMENSIONS**

**SPECIFICATIONS**

**HEAT RELEASE REQUIREMENTS**

QR LINK FOR  
PDF DIGITAL COPY  
OF SPECIFICATIONS:



# ZCVRB47 –Unvented Chase VS Vented Chase- Choose Your Installation

Look at the following chart before you begin the installation.

	Low Enclosure	Wall Surface Temperature above front of fireplace	TV above Fireplace with Recessed Installation option	Mantel Height (From Bottom of Unit)	Heat can be directed to second room
<b>UNVENTED CHASE</b>	70"	Warm	Yes	2" at 41-7/16"	No
<b>VENTED CHASE</b>	70"	<b>40% Cooler</b> than unvented chase	Yes (Recommended)	Any size at 39-7/16"	Yes

## FRAMED AS

### UNVENTED CHASE:

This is a traditional fireplace installation where the fireplace is built into an unvented chase.

- **Non-Combustible Materials Must be used** on face of fireplace
- Wall surface temperature will be moderately hot
- TV above Fireplace is allowed
- Mantel height is higher

Fireplace will be installed with Ventilation Plates in place (as shipped).

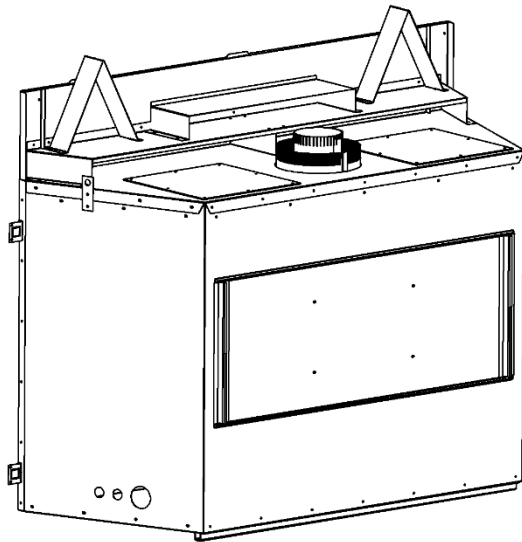

See "Unvented Chase" Framing Section

## FRAMED AS

### VENTED CHASE:

The fireplace is installed into a vented chase. There are many different styles of vented chase. See pages in manual for installation details and information.

- **Non-Combustible Materials Must be used** on face of fireplace
- Chase walls will be cool to the touch.
- A TV is allowed above the fireplace.
- Mantel height is lower

Fireplace will be installed with **Ventilation Plates** removed (see instructions in manual).

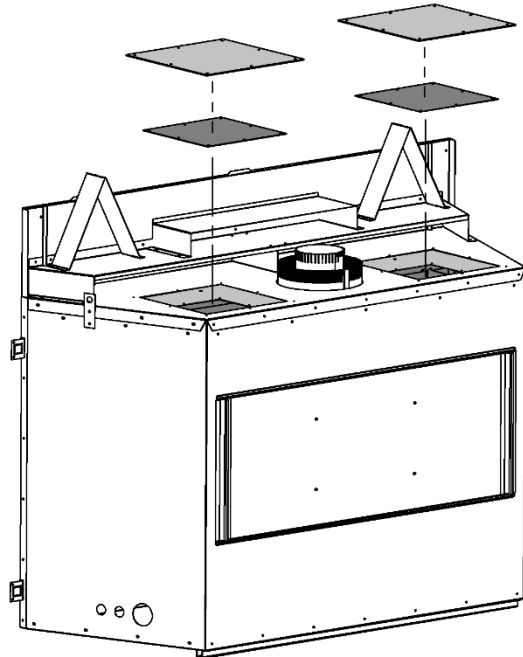

- A minimum opening of 105 square inches of ventilation area is required.
- Kingsman **V46EG** or **VL60EGS** Grills may be used.
- If a custom grill is used, free air opening must total 105 square inches with no sloping louvers.

See "Vented Chase" Framing Section

**⚠ CAUTION: IF VENTILATION PLATES ARE REMOVED, YOU MUST VENT THE CHASE!**

## ZCVRB47 -Facing Requirements

An **Unvented Chase** requires **Non-combustible covering (i.e., concrete board)** over the front face of the appliance.

A **Vented Chase** requires **Non-combustible covering (i.e., concrete board)** over the front face of the appliance.

**Notice:** Granite, tile, or other facing materials are not covered by the fireplace warranty. Natural stone, tile, and other facing materials may crack or discolor (i.e. yellowing of lighter colored materials).

**NOTE: these issues can be avoided if the Chase is Vented.**

**Televisions are not covered by fireplace warranty.**

**Notice: DurockR Brand Cement Board:** The manufacturer recommends **CGC SheetrockR Brand DurabondR 90 Setting- Type Drywall Compound** rather than a ready-mix product for finishing.

When finishing the wall around the fireplace, it is critical that the wall covering be fastened properly. It is acceptable to pre-drill holes and use self-tapping screws which may be used to fasten a backer for tile, marble, etc. Screws being installed through non-combustible board should be self-tapping type with a maximum length of 2 inches.

**Do not drill or install longer screws (over 2") as this may damage internal components.**

- We recommend that CONCRETE BOARD (non-combustible material) be tied in to the entire perimeter of the fireplace for durability.

**Finishing Recommendations** (Obtained from professional construction contractors and finishers):

- Frame unit with metal studs (minimum 20 gauge). **Wooden studs may be used, but may cause drywall screws to pop or pull due to wood studs drying out.**
- Minimum of 1/2" CONCRETE BOARD cement board (this **non-combustible** panel is ULC listed as a wall shield/floor protector) and fasten to the entire perimeter framing.
- Use fiberglass (mesh) tape for all joints in area of the fireplace.
- Use Yellow joint mud (contains high amounts of glue) – two coats, finishing with one coat of green topping mud, sand and prep for painting.
- If not using a surround, a metal "L" Trim may be used to finish perimeter of CONCRETE BOARD.
- OTHER NOTES:
  - A full single sheet of non-combustible board (no joints) above the unit is recommended if possible.
  - It is preferred to attach the non-combustible board to **framing only** and not directly to the unit to allow for expansion and contraction during normal operation.
  - Lighter colored painted surfaces may discolor due to heat exposure.

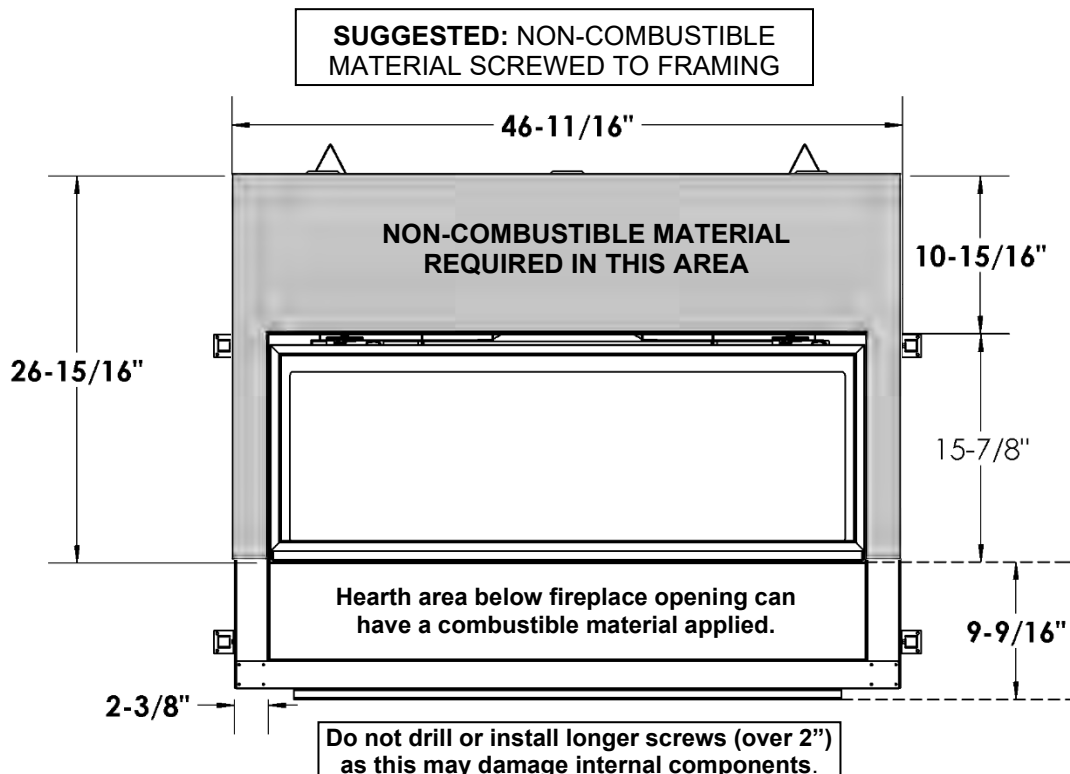

This section is intended for qualified installers only. Before beginning, make note of where the gas and electrical accesses are located on the unit. This will streamline the construction process. Furthermore, familiarize yourself with the venting and clearance requirements (see Venting section) for this appliance. Failure to comply with those requirements can seriously compromise the safety and operation of the fireplace.

**Specifications**

1. Cold climate installation recommendation: When installing this fireplace against non-insulated exterior wall or chase, it is recommended that the outer walls be insulated to conform to applicable insulation codes. Drywall & vapor barrier must be installed over insulation to prevent contact of insulation and unit.
2. Choose fireplace location and frame in accordance with the fireplace framing dimensions specified (view diagrams).
3. Drywall or other combustible material can extend up to the Drywall Stops located on the sides of the unit, and up to the bottom and top.
4. A Hearth is not required for this unit.

**Vertical Venting in Cold Climates**

In cold climate conditions where temperatures go below -10 degrees Celsius or 14 degrees Fahrenheit, we recommend that the chase be insulated and where the vent pipe enters into the attic space that the pipe be wrapped with an insulated Mylar sleeve. This will increase the temperature of the vent and help the appliance to vent properly in cold weather conditions.

It is also important in vertical vented direct vent appliances that the appliance be operated daily during the winter months as this will help stop the termination from freezing up. We recommend using a thermostat (Not permitted for decorative vented gas fireplaces installed in the U.S.A.) set at room temperature to allow the unit to cycle.

For IPI models it may be necessary to set the appliance to Standing Pilot mode to maintain heat in the cavity. The purpose of this procedure is to prevent cold air from penetrating the chimney and then onto the living space. Therefore, when the internal temperature is slightly elevated the fireplace is able to freely exhaust its combustion and hence making it easier to startup.

Certified for installation in a bedroom or bedsitting room. In Canada must be installed with listed millivolt thermostat (Not permitted for decorative vented gas fireplaces installed in the U.S.A.). In USA see local codes.

**Stand-off Locations**

Make note of where the stand-off locations are. These stand-offs are provided as indicators to illustrate the boundaries for framing. Therefore, no framing material is permitted to extend beyond these stand-offs.

**Caution:** Standoffs on top of the unit must be folded into position & screwed down prior to installation.

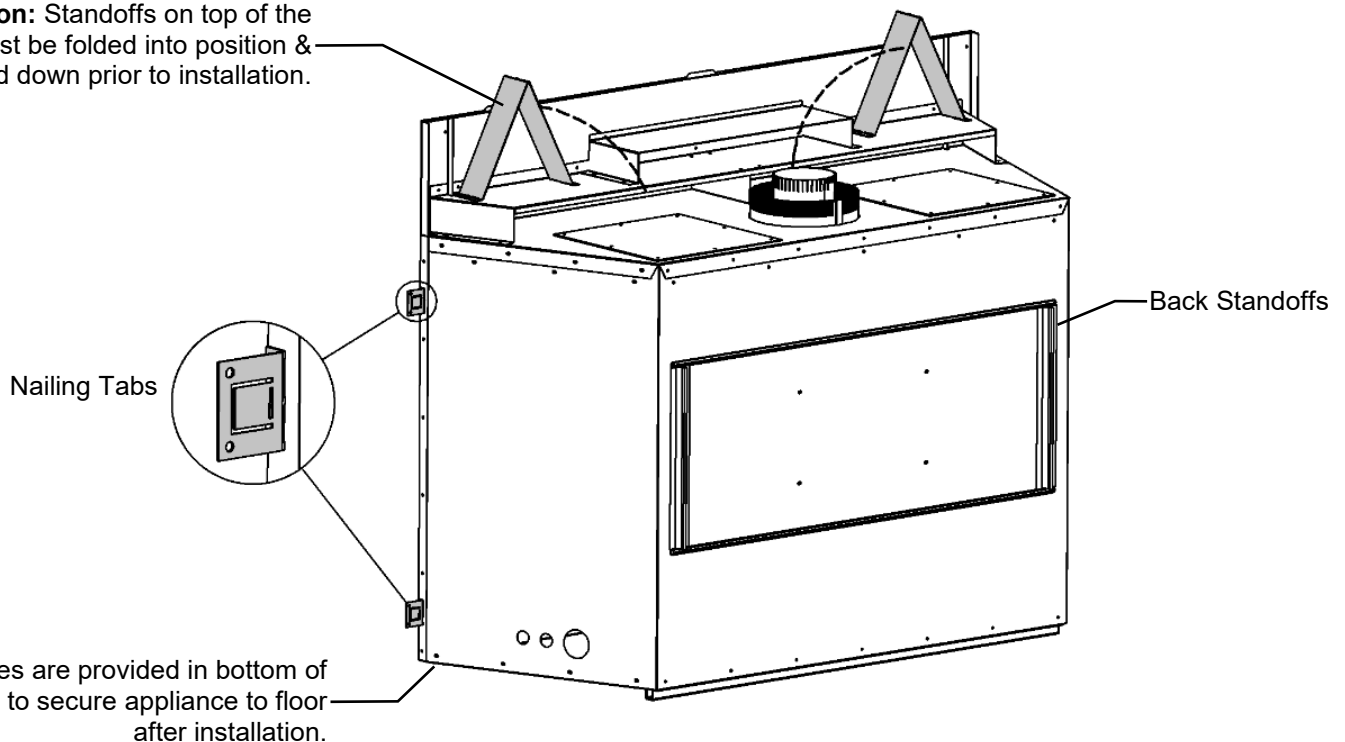

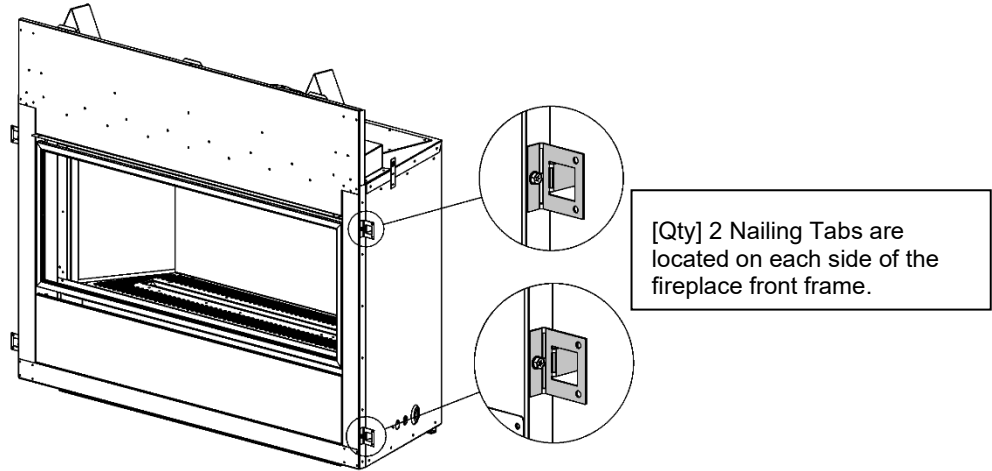

**These Nailing Tabs can be used in two ways:**

**1/2" Drywall Flush with Face of Fireplace**

Fireplace and Combustible Wall to be covered with a surround and / or Non-Combustible Materials (e.g. Stone around Fireplace).

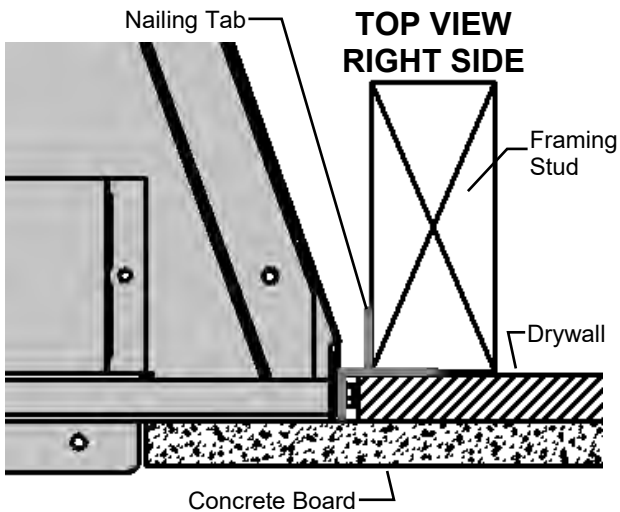
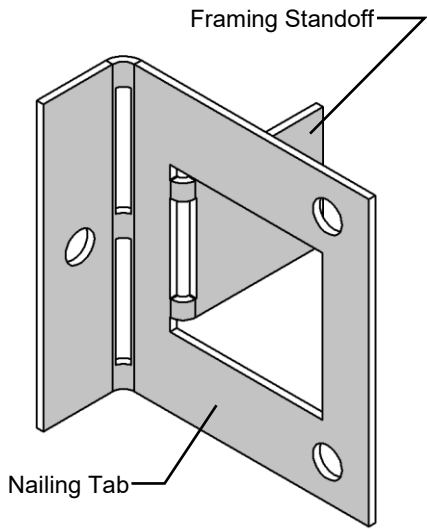

**Framing Flush with Face of Fireplace**

Fireplace to be covered with Non-Combustibles (e.g. Concrete Board) for **Flat Wall** appearance.

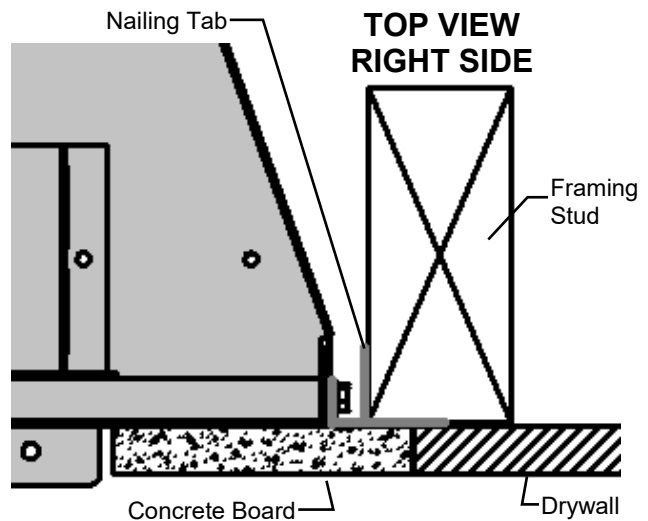
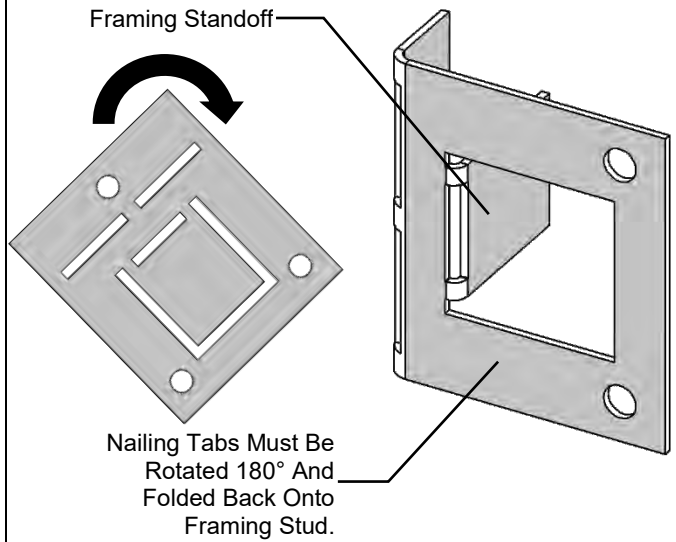

# ZCVRB47

# Locating Your Appliance

### LOCATION KEY:

- A. Flat on Wall
- B. Across the Corner
- C. As an Island
- D. As a Room Divider
- E. Flat on Wall Corner
- F. Exterior Wall

See Mantel Leg Clearances Instruction for the proper placement of fireplace.

Island installation with a top vent is possible as long as the horizontal portion of the vent system does not exceed 20 feet (6.1 m).

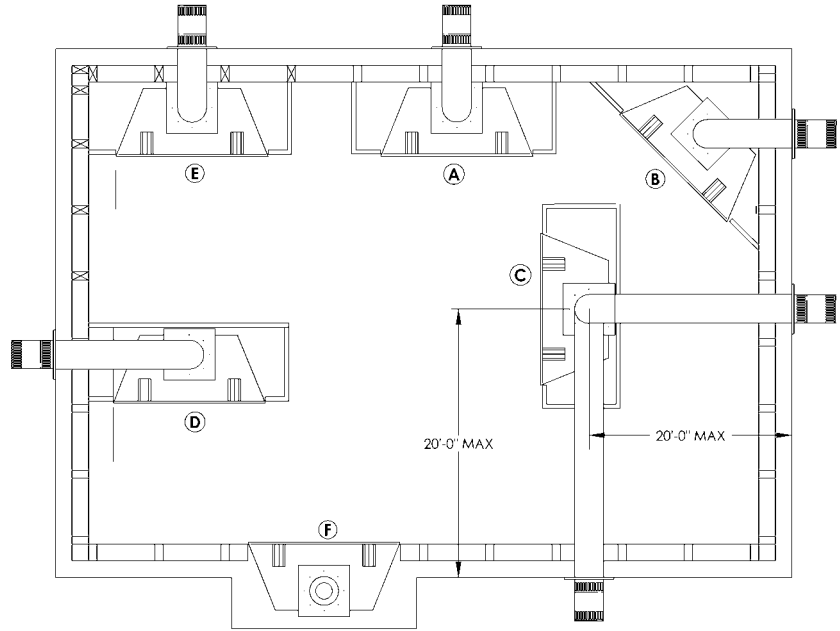

# ZCVRB47

# Fireplace Dimensions

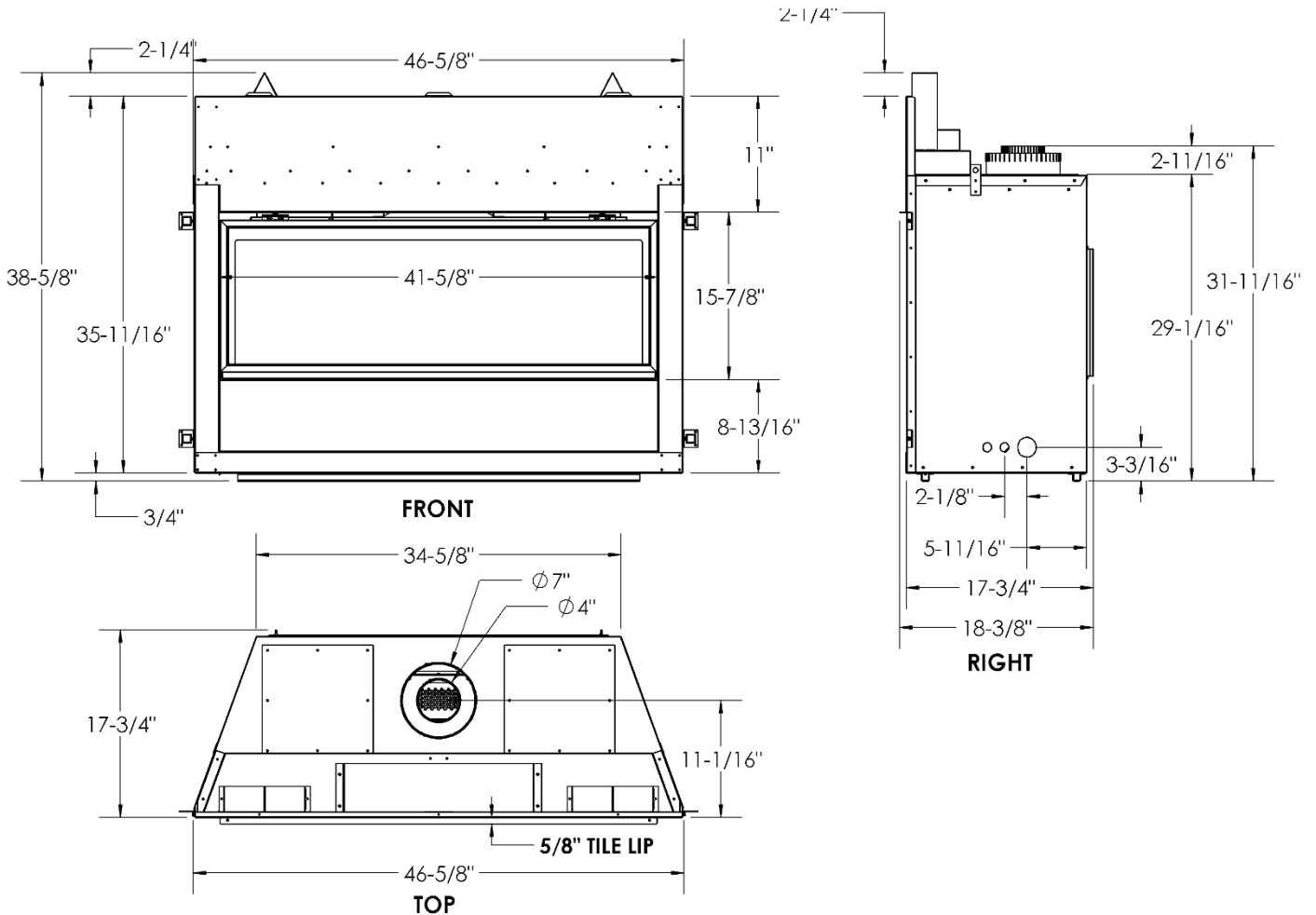

# ZCVRB47- Framing Dimensions –Unvented Chase-Ventilation Plates In Place- As Shipped

Determine whether face of fireplace will be:

- Flush with finished wall (e.g., for surround, cultured stone or other non combustible covering).
- Flush with framing (to be covered with concrete board for a Flat Wall appearance).
- Refer to Nailing Tab Guide section also.

**These structures are not load bearing.**

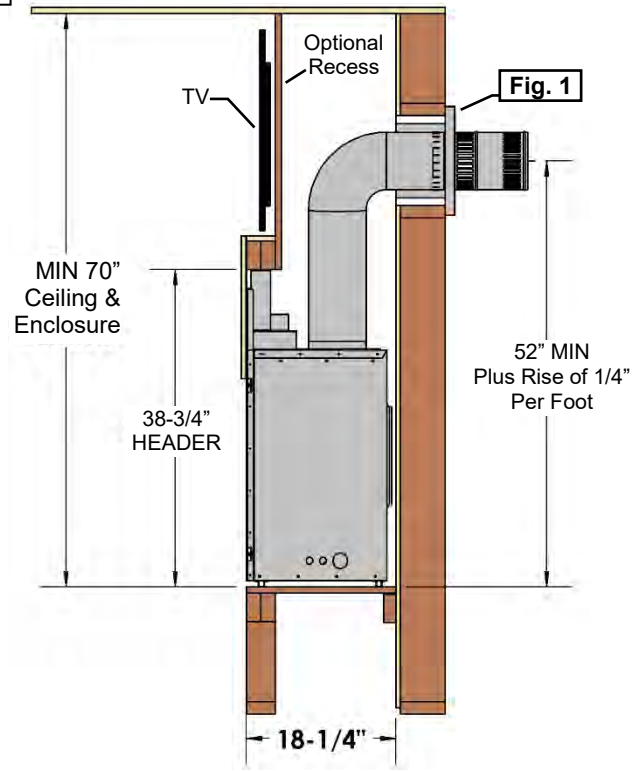
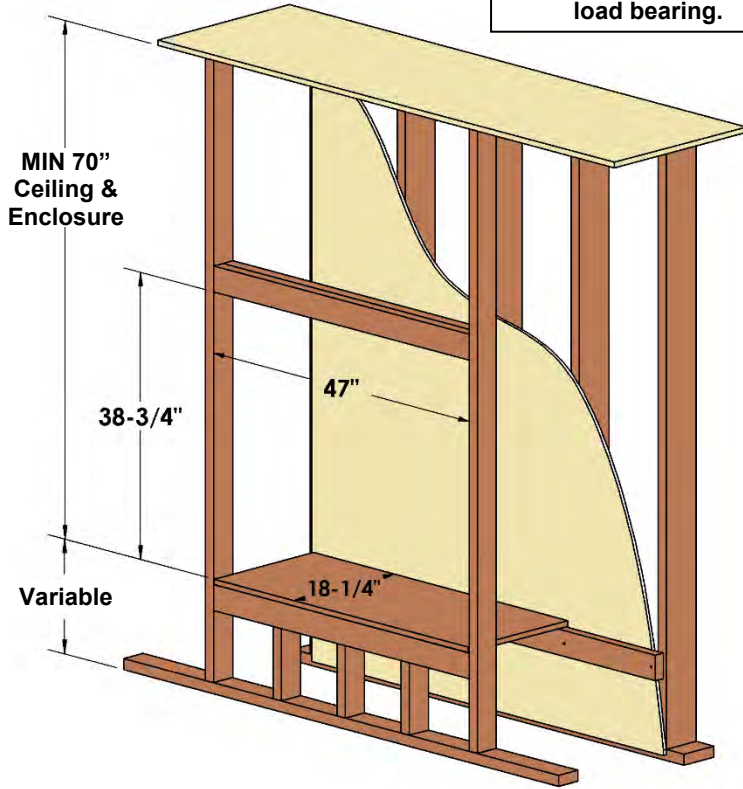

Note: If using optional surround, maximum thickness for non-combustible material is 1-1/8".

**Vertical Venting MUST maintain 1" clearance to combustibles.**

**Fig.1**  
Framing for Horizontal Vent Termination  
(See Installation of Side Wall Venting Section)

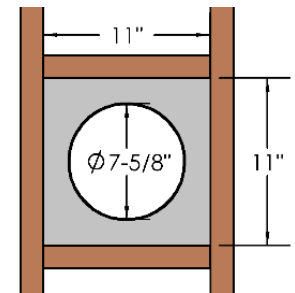
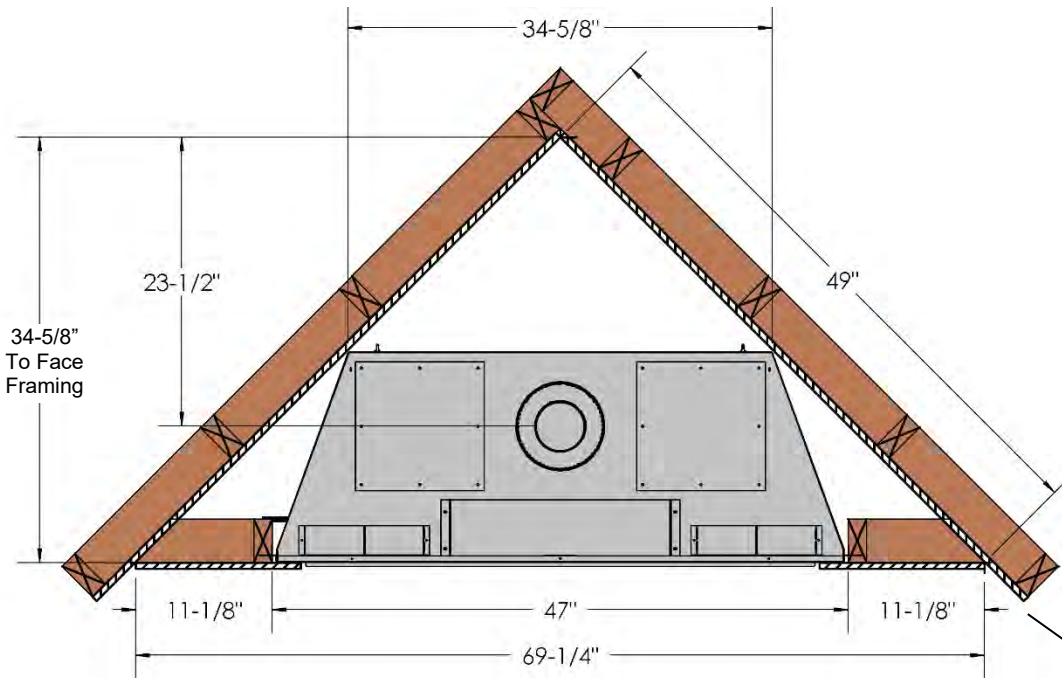

## ZCVRB47 -Mantel Clearances –Unvented Chase- Ventilation Plates In Place -As Shipped

Before installing any mantels it is important to determine the combustibility of its material(s). There are two types of mantels to consider: Combustible and Non-Combustible.

A **Combustible Mantel** is one that consists of material(s) that may discolor, combust, or lose its integrity in the presence of heat. These types of mantels must strictly conform to the dimensional requirements shown.

Conversely, a **Non-Combustible Mantel** is one that is constructed with material(s) that will not combust. Check your local codes and regulations to determine whether your mantel is Combustible or Non-Combustible.

The advantage to Non-Combustible Mantels is that it may extend right up to the tile lip of the fireplace. Combustible mantels must adhere to the dimensional restrictions shown.

Mantel Dimensions are from front face or Non-Combustible Facing Materials covering fireplace.

Combustible Mantel Line

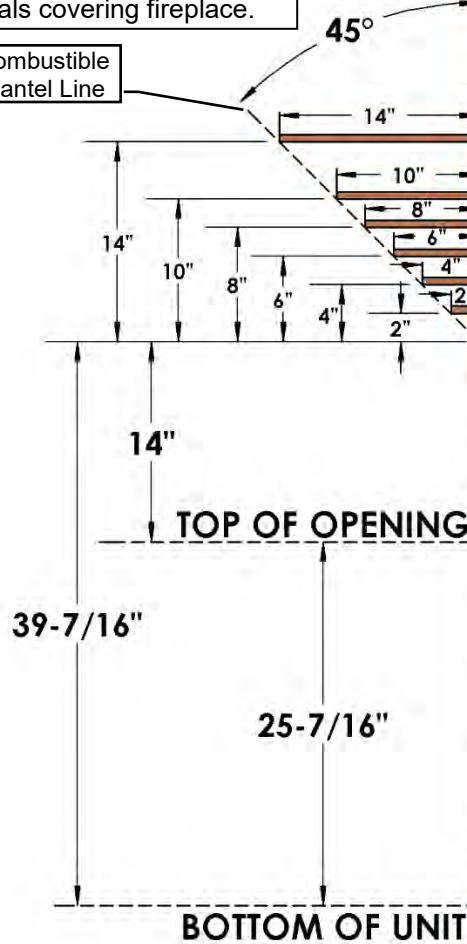

### **⚠️ Combustible Objects on Non-Combustible Mantel Warning-**

Combustible objects must not be placed on a Non-combustible Mantel unless the mantel meets the dimensional requirements for a Combustible Mantel. Determine whether your mantel conforms to the requirements of a Combustible Mantel.

## Mantel Leg Clearances

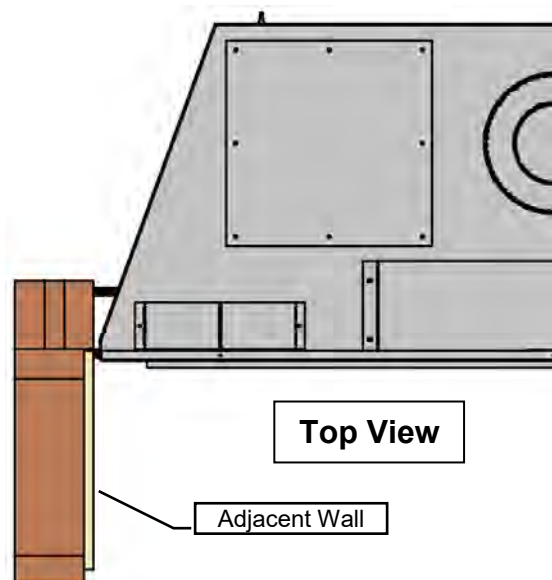
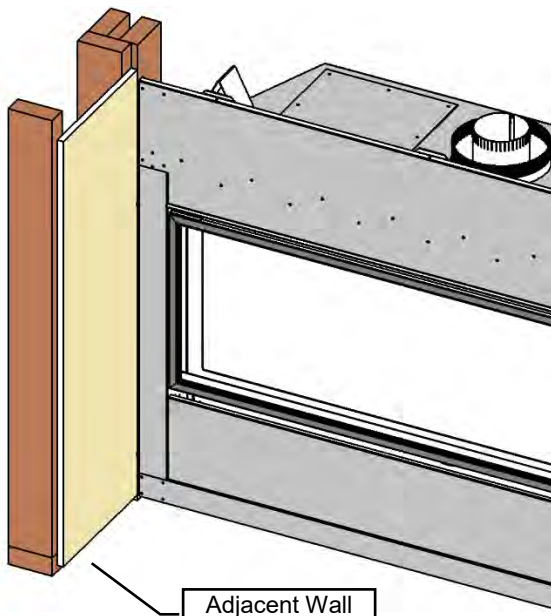



# ZCVRB47 -Clearance to Combustibles –Unvented Chase- Ventilation Plates In Place – As Shipped

Clearance to Combustibles	ZCVRB47 Unvented Chase
Front	36" [92cm]
Back (from Stand-offs)	0" [0cm]
Side (from Stand-offs)	0" [0cm]
Floor	0" [0cm]
Minimum Ceiling Height (from bottom of fireplace)	70" [179cm]
Top (from Stand-offs)	0" [0cm]
Top of 90° Bend in minimum Enclosure of 70"	4" [10.2cm]
Top of 90° Bend in Enclosure over 70"	4" [10.2cm]
<b>VENTING SYSTEMS</b>	
Top of Horizontal Pipe	1/1/2" [3.8cm]
Side & Bottom of Horizontal Pipe	1" [2.5cm] All Vent Systems
Vertical Vent Pipe	1" [2.5cm] All Vent Systems
<b>REFER TO FACING REQUIREMENTS SECTION FOR FACING MATERIALS</b>	

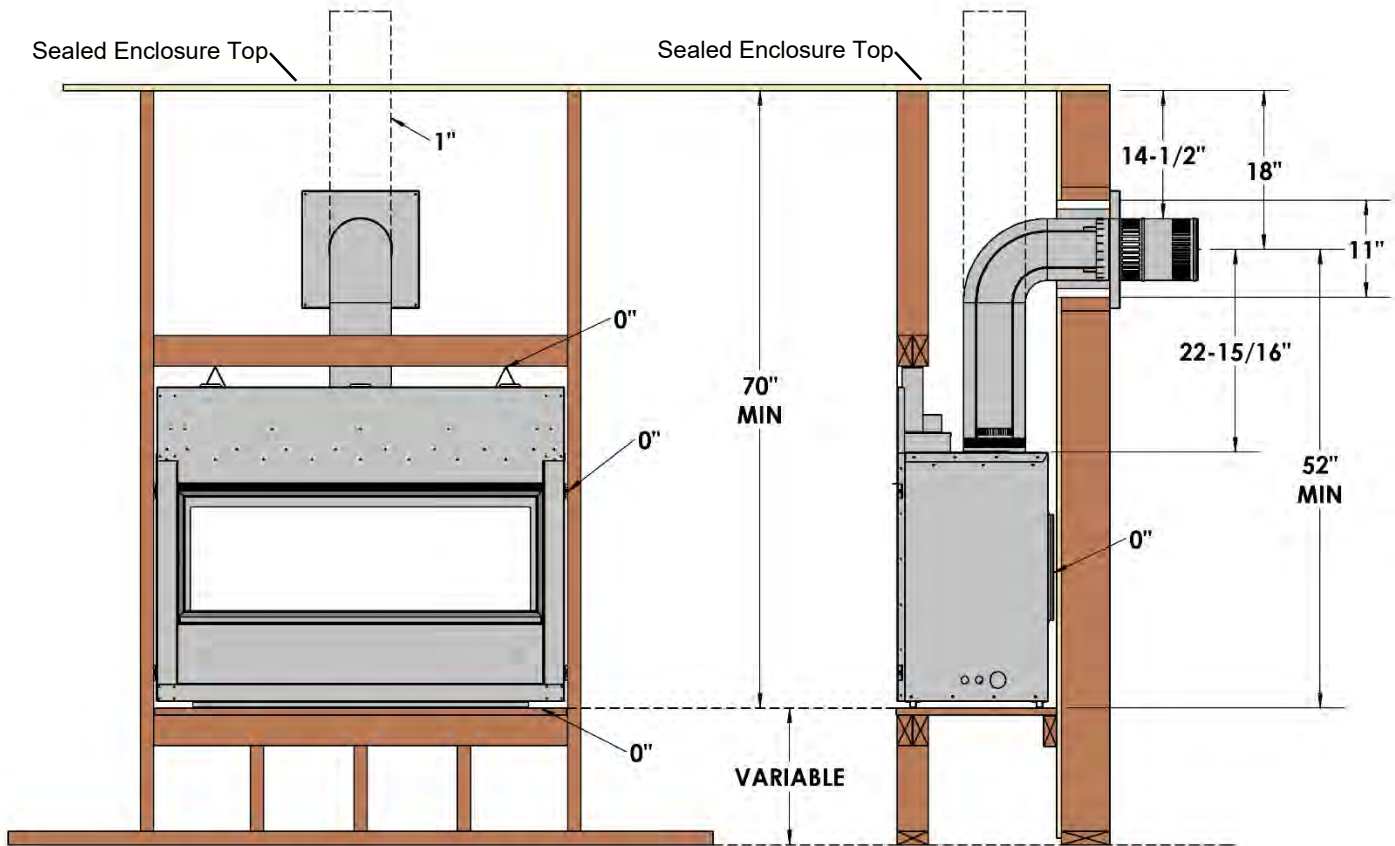

**⚠ NOTE:** If using insulation in unvented chase (i.e. for outside wall), wall board / drywall is required to support all insulation. Unvented chase must be clean and free of all debris (i.e. loose insulation, pieces of wood, etc.).

**⚠ NOTE:** HEAT CANNOT BE DISCHARGED INTO THE WALLS, FLOOR, OR CEILING.